

SUSPENSION INSULATORS

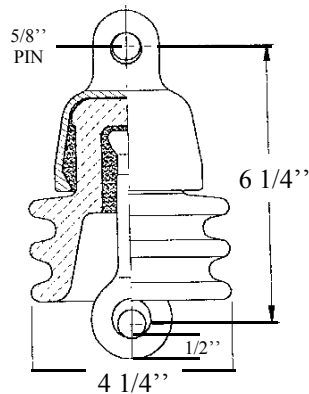

FIG. 1

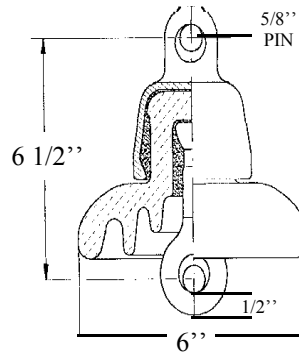

FIG. 2

CATALOG NUMBER	ANSI CLASS	COMBINED M & E STRENGTH	MECH. IMPACT STRENGTH	TENSION PROOF	LOW FREQUENCY FLASHOVER		IMPULSE FLASHOVER		LOW FREQ. PUNCTURE
					DRY	WET	POS.	NEG.	
U52 - 9G	52 - 9	10,000 LBS.	55	5,000 LBS.	60 kV	30 kV	100	90	80 kV
U52 - 1G	52 - 1	10,000 LBS.	45	5,000 LBS.	60 kV	30 Kv	100	100	80 kV
U52 - 2G	52 - 2	15,000 LBS.	50	7,500 LBS.	65 kV	35 kV	115	115	90 kV

DIMENSIONS AND WEIGHTS

CATALOG NUMBER	FIG. NO.	LEAKAGE DISTANCE	DRY ARCING DISTANCE	INSULATOR SPACING	NOMINAL DIAMETER	WEIGHT PER 100
U52 - 9G PICTURED	1	7"	4"	6 1/4"	4 1/4"	555 LBS.
U52 - 1G PICTURED	2	7"	4 1/2"	5 1/2"	6"	570 LBS.
U52 - 2G	2	8 1/4"	6"	5 3/4"	8"	880 LBS.

THE ABOVE SUSPENSION INSULATORS ARE OFFERED IN A "SKY GRAY" GLAZE.
FOR BROWN GLAZE, CHANGE THE SUFFIX "G" TO A "B".
EACH OF THESE INSULATORS HAVE A MAXIMUM RIV OF 50 MICROVOLTS.

SUSPENSION INSULATORS

5-10

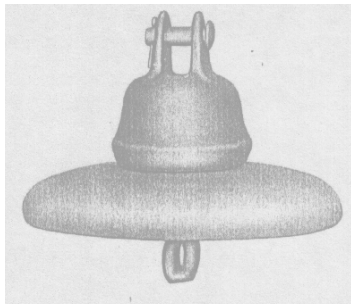

CLEVIS & TONGUE

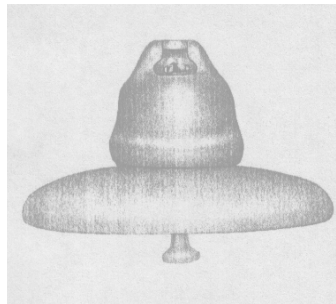

BALL & SOCKET

CATALOG NUMBER	U52 – 2G	U52 – 3G	U52 – 4G	U52 – 5G	U52 – 8G
ANSI TYPE	52 – 2	52 – 3	52 – 4	52 – 5	52 – 8
STYLE NUMBER	1.136	1.100	1.031	1.059	1.221
NOMINAL DIAMETER	8"	10"	10"	10"	11"
NOMINAL SPACING	5.75"	5.75"	5.75"	5.75"	5.75"
TOTAL CREEPAGE	8.25"	12.6"	12.6"	12.6"	14.5"
COUPLING TYPE & SIZE	TONGUE & CLEVIS	BALL & SOCKET TYPE B	TONGUE & CLEVIS	BALL & SOCKET TYPE J	BALL & SOCKET TYPE K
LOCKING DEVICE	—	R	—	R	R
ELECTRO MECHANICAL RATING	15000 LBS.	15000 LBS.	15000 LBS.	25000 LBS.	36000 LBS.
IMPACT STRENGTH	50	55	55	60	90
TENSION PROOF	7500 LBS.	7500 LBS.	7500 LBS.	12500 LBS.	18000 LBS.
DRY P.F. FLASHOVER	65 kV	80 kV	80 kV	80 kV	80 kV
WET P.F. FLASHOVER	35 kV	50 kV	50 kV	50 kV	50 kV
IMPULSE WITHSTAND +	100 kVp	110 kVp	110 kVp	110 kVp	110 kVp
IMPULSE WITHSTAND -	100 kVp	110 kVp	110 kVp	110 kVp	110 kVp
PUNCTURE VOLTAGE	90 kV	120 kV	110 kV	130 kV	140 kV
RIV TEST VOLTAGE	50 uV	50 uV	50 uV	50 uV	50 uV
CORONA EXTENSION	09 kV	09 kV	09 kV	09 kV	09 kV
NET WEIGHT EACH	8.8 LBS.	11.5 LBS.	11.5 LBS.	13.7 LBS.	17.5 LBS.
STANDARD PACKAGE	6	6	6	6	3

THE ABOVE INSULATORS ARE OFFERED IN A "SKY GRAY" GLAZE.
FOR BROWN GLAZE, CHANGE THE SUFFIX "G" TO "B".